

BaSyTec

Battery - System - Technology

RPS

High Power

Battery Test System

with Energy Recovery



- ✓ Research
- ✓ Development
- ✓ Production
- ✓ Quality control

Optimized for high throughput of cells

BaSyTec is one of the leading manufacturers of battery test systems. Several hundred systems are operated today all over the world. Customers are battery manufacturers, universities, test laboratories, car makers, power tool manufacturers and producers of electronic equipment.

Main Features

The RPS system is optimized for testing of large batteries and for high power batteries. The systems are customized according to your requirements. The key parameters therefore are maximum power, voltage and current. The key features are:

- Charge and discharge current of up to 600 A
- Voltage of up to 1000 V
- Continuous power of up to 400 kW
- Current rise time below 3 ms
- Energy recovery while discharging with high efficiency
- Batteries are connected in four wire method
- Low current ripple of below 0.3%
- Low line perturbation by use of power factor correction
- Optional battery safety device for independent battery monitoring and emergency shut-off
- Interface for climate chamber and other third party devices (like BMS systems)
- Interface to superordinate safety concept
- CMU Datalogger with up to 4800 inputs for temperatures and voltages available
- Software compatible with all other BaSyTec battery test systems



The RPS system is optimized for high power and high energy automotive systems, like HEV, PHEV, EV and SLI batteries and dlc.



RPS Battery Test System

Typical Applications

The BaSyTec RPS test system is optimized for battery modules and battery systems (Li-Ion, NiMH, NiCd, Lead-Acid, DLC). The energy recovery makes testing of large systems and of high power systems more economic. Typical applications are

- Life cycle tests of battery modules and battery systems
- Parameter tests of battery modules and battery systems
- Application oriented tests
- Simulation of current profiles with high current dynamic
- Double layer capacitor testing



Battery safety devices

The Innovative Concept

Technology

The RPS system is based on a modern IGBT rectifier/inverter followed by a fast chopper. This technology allows energy recovery back to the power line while discharging in combination with a fast response time and a low current ripple. A transformer guarantees the galvanic isolation from the power line. The efficiency of the energy recovery is up to 95%. In comparison to systems without energy recovery, the advantages are:

- Lower direct energy costs
- Lower heat dissipation
- Better room use
- Lower indirect costs for air condition

The repayment of the higher costs by the lower energy requirement depends on the usage of the test system and can be achieved within 1 to 2 years.

High Reliability

The RPS system operates at high reliability. The power electronic is made by Gustav Klein GmbH & Co KG, a company with more than 60 years of experience in such systems. The control electronics and control software is the approved BaSyTec system. Several 100 battery test systems are operated today world wide. The high reliability is caused by the embedded control that is independent from the operation of a PC and networks. The test procedure is transmitted to the test system where it is executed in an embedded controller.

A hierarchical watchdog system detects failures of the test system and shuts down the system in undefined conditions. An independent battery safety device (BSD) monitors all relevant battery signals, as voltage, current, cell voltages, temperatures and other signals, and initialize an emergency stop if any signal exceeds its limit.

The BaSyTec battery test system can be integrated into a superordinate safety concept.

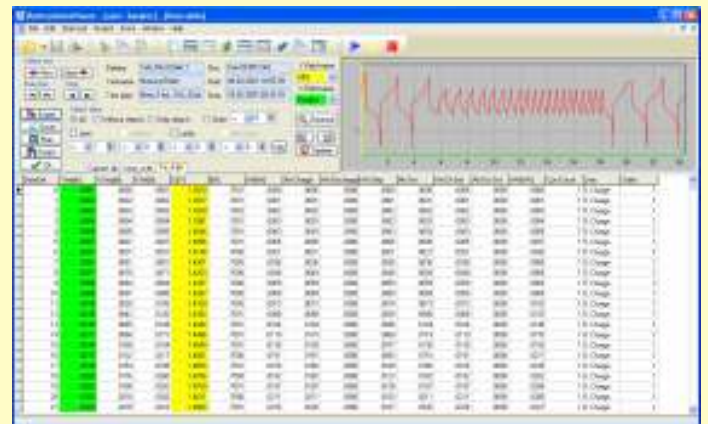
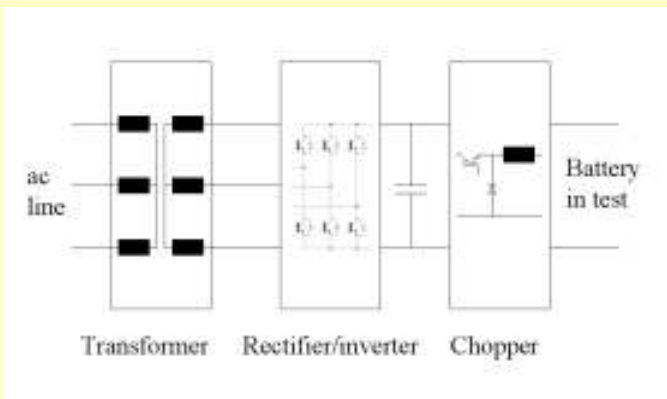

Battery Simulation

All BaSyTec RPS battery test systems can be switched to act as a **bipolar laboratory power supply** (source and sink). Output voltage, resistance and current limits are set at the display and the keys on the front panel.

In this mode they offer a CAN interface where output voltage and internal resistance can be set dynamically so the BaSyTec RPS battery test system can be used as a battery simulator or as the power electronics for a motor test bench as well.

Software

The BaSyTest software is used to define test procedures, to control the battery test system, to monitor running tests and to analyze test results. Tests are defined by a test plan written in the integrated test plan editor. Constant current, constant voltage and constant power control modes are possible. For discharging also constant resistance. The test procedures are downloaded to the test system where they are running independently from the PC.

Technical Specification

Power	up to 400 kW
Voltage range	up to 1000V
Voltage precision	0.05% FS
Voltage resolution	16 bit full scale
4-wire measurement	Yes
Min. voltage	5% of full scale
Current range (charge + discharge) per channel (can be paralleled)	up to 600 A (customized)
Current precision	0.05% FS
Current resolution	16 Bit
Add. inputs per channel	2 x PT 100/4-wire temperature Others optional
Inputs / BSD HV (option)	Voltage, current 2 x PT 100/4-wire temperature 4 x 0-10V (for sensors) 11 x 0-100V (module voltages)
Time resolution	1 μ s
Minimum pulse length	5 ms
Current rise time	< 3ms
Current ripple	< 0.3%
Efficiency in recovery mode (discharge) at rated power	95%
Power factor	> 0.99
Control mode	constant current, constant voltage, constant power, constant resistance, voltage ramp, current ramp, table defined profiles
Software	BaSyTest
Interface	Ethernet
Battery protection	BaSyTec Battery Safety Device (BSD) with emergency stop
System protection	Hierarchical watchdog system
Weight and size	customized
Input current / input power	customized

BaSyTec GmbH

Oellinger Weg 17, 89176 Asselfingen, Germany

Tel.: +49-7345/238 500, Fax: +49-7345/238 725, www.basytec.com